



INTERNATIONAL JOURNAL OF ENGINEERING SCIENCES & RESEARCH TECHNOLOGY

ANALYZING THE PERFORMANCE OF GRID – CONNECTED PV SYSTEM

Rocky Chhikara*, Neha Mehta

* Electronics and Communication Department, Sat Kabir Institute Of Technology and Management,
Haryana, India.

ABSTRACT

In the last few years, the demand for renewable energy has increased significantly due to the disadvantages of conventional fossil fuels and greenhouse gas effect. Among various types of renewable energy resources, solar energy and wind energy have become the most promising and attractive because of advancement in power electronic technique for production of electricity. Photovoltaic (PV) sources are used nowadays in many applications because they have the advantage of being maintenance free and pollution free. The fuzzy PI current controller is produced low harmonic distortion and improved sudden steps response compared to PI current controller.

KEYWORDS: renewable energy, fossil fuels, solar energy, photovoltaic, harmonic distortion.

INTRODUCTION

According to European Photovoltaic Industry Association (EPIA), at the end of 2012, total installed PV capacity in the world has reached over 70 GW with an increase of 72% increase in 2011. Europe still leads the market with over 55 GW of cumulative power installed. Italy became for the first time the top PV market in 2012 with 10GW of newly installed Capacity with an impressive 290% rise. The high uses of PV technology was induced by continuous increase of energy price generated in coal, diesel and gas power plant. PV system have been required to reduce costs in order to complete the demand of population and compete on energy market but on the same time to provide reliability. Usually reliability of a PV system is associated with inverter topology and the main components.

The fast expansion and development of PV system into the lower parts of grid raised several concerns for grid reinforcement. This is the reason, grid

operators had to impose strict operational rules in order to keep the LV grid under control and to harmonize the behavior of all distributed generators connected to it in terms of accuracy, efficiency and prices.

As the efficiency of PV system is growing significantly, the effect of PV modules on power grid can't be ignored. They can create problems on the grid like flicker, increase of harmonics, and aggravated stability of the power system. To both increase the capacity of PV arrays and maintain power quality, it's necessary to meet with the technique requirements of the PV system, such as fault ride through proficiency and harmonic current increment. Especially when a large scale PV module is connected to the grid, the effects on the grid may be quite severe. Therefore, the system activity and system stability under fault conditions should be checked when PV modules are connected with power grid.

MATERIALS AND METHODS

Theoretical Development

Photovoltaic (PV) are solid-state, semi-conductor type devices that generate electricity when kept to light. The word photovoltaic actually means "electricity from light." Many handheld calculators run off power from room light, which would be one example of this activity. Larger power applications for this are also possible. Photovoltaic are the direct conversion of light into electricity at the atomic level. Some Materials shows a property known as the photoelectric effect that

causes them to absorb Photons of light and release electrons. When these free electrons are arrested electric current results that can be used as electricity. A photovoltaic cell or photoelectric cell is a semiconductor device that converts light to electrical energy by photovoltaic effect. If the energy of photon light is greater than the band gap then the electron is emitted and the flow of electrons creates current. However a photovoltaic cell is different from a photodiode. In a photodiode light incidents on n channel of the semiconductor junction and gets converted into current or voltage signal but a photovoltaic cell is always forward biased.

Photovoltaic Module

PV cells are the basic building blocks of PV modules. For almost all applications, the one half volt produced by a single cell is insufficient. Therefore cells are attached together in series to gain the voltage. Some of these series strings of cells may be connected in parallel to increase the current as well. Modules come in different standard sizes and can also be custom-made by the manufacturer. These modules consist of a series of interconnected PV cells, laminated between glass and a black sheet and held within a rigid aluminum frame. PV modules are usually the most cost effective solution and can be combined to form an array of the correct size for your building and electricity demand.

Grid connected PV system

As day by day the demand of electricity is increasing and that much demand pollution also. Grid tied PV system is more reliable than other PV system. In this type of system, battery is not used, so capital cost reduces and therefore we use grid connected topology. If generated solar energy is integrated to the conventional grid, it can accumulate the demand from morning to afternoon that is the particular time range when the SPV system can fed to grid. Grid interconnection of photovoltaic power generation system has the advantage of more effective utilization of generated power. Grid interconnection of PV systems is fulfilled through the inverter, which changes DC power produced from PV modules to AC power used for ordinary power supply for electrical equipments. Inverter technology is very important to have reliable and safety grid interconnection operation of PV system. The accepted model of PV grid connected system cannot only realize photovoltaic generation, but also repress current harmonics, reduce reactive power, remove voltage sags or swells and other power quality problems. An adaptive predictive maximum power point tracking (MPPT) algorithm is employed to improve the efficiency of PV generation.

To make the control simple, the synchronous frame method is inserted in modeling the inverter. The form of a faster internal current control loop and a slower external voltage control loop is used in order to obtain a good dynamic response. Grid connected PV generation is one of the major development trends of photovoltaic operations. At the same time, with the development of the power electronics industrialization process, a large no. of nonlinear loads has appeared. Harmonics and reactive current from nonlinear load induce that the power quality problems become more and more serious. PV grid connected generation operates during the day and has to stop at night. This affects the steady state of power system and the utilization of equipment. Therefore in order to increase the utilization, the PV system can be structured to also provide the function of power quality managements.

THE PROPOSED GRID-CONNECTED PV SYSTEM

The unified system is composed of PV generation and energy storage system and the power quality inclusive compensator. Solar energy is converted into electricity through PV array. Then the voltage across PV array is amplified with a unidirectional dc/dc boost converter so as to track the maximum power point of PV array conveniently. After that, the dc/ac inverter converts dc power into ac power which is injected into the utility grid or directly supplies to local loads. At the same time the system can give a strongly voltage compensation when the grid voltage sags or swells because it is equipped with large capacity storage devices. PV array also increases the ability of its power compensation. When the grid voltage rises in a sudden manner, the batteries are charged in quick succession, accepting energy from the grid, thereby the grid voltage swells is kept under control. In the same way, when the grid voltage drops suddenly, the batteries release energy quickly to grid, suppressing the voltage sags. Compared to the conventional photovoltaic generation devices, it can not only inject active power into grid, also has the objectives of reactive power compensation and harmonic repression, removing grid voltage drops and swells. In addition, the system can work as shunt active power filter and UPS in the absence of sunshine or the weak sunshine.

The proposed inverter topology

The proposed inverter topology is comprises of PV array, DC-DC boost converter, five-level H-bridge inverter, grid-connected.

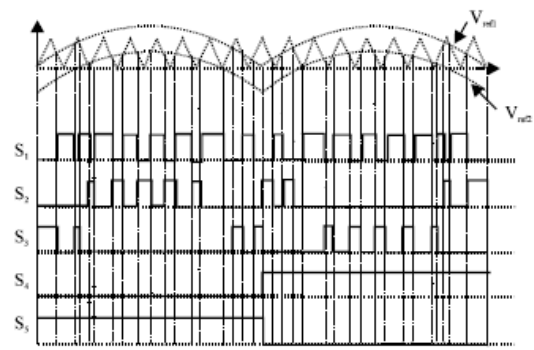
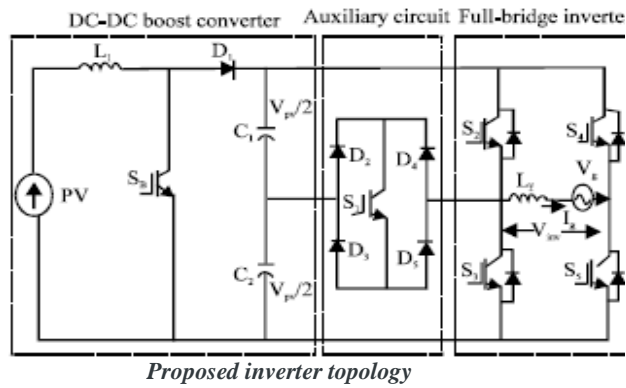

Switching pattern for the single-phase five level inverter

The PV array produced dc supply through solar energy, its low level dc output. In low level dc output step up high level voltage through DC-DC boost converter with dc bus capacitors. The step up ratio of boost converter is 1:2. The five-level inverter is used to change of DC to AC voltage. The inverter is connected to grid-system i.e., utility feeder through filtering inductor. The current injected in grid must be sinusoidal with low harmonic distortion. The load is assumed as resistive and inductive load.

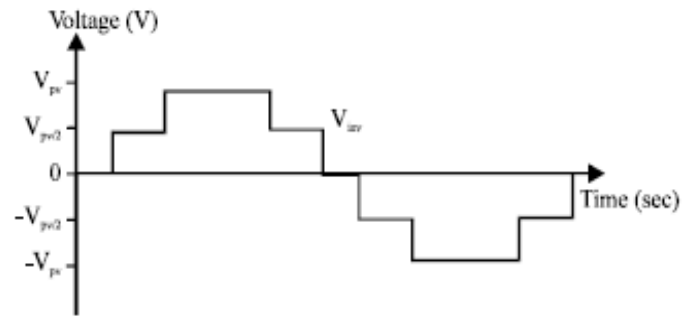

Ideal five-level inverter output voltage \$V_{inv}\$

MODULATION TECHNIQUE AND PROPOSED INVERTER'S OPERATION

A sinusoidal PWM is used, it is one of the most efficient method. The suggested PWM modulation strategy is shown in Fig. Two reference signals \$V_{ref1}\$ and \$V_{ref2}\$ and triangular carrier signal \$V_{carrier}\$ were used to generate the PWM switching signals. The modulation index \$M_a\$ is maintained between 0-1. The output voltage is originated by comparison of the two reference signals and the carrier signals can be expressed as fourier series coefficient:

$$V_o(\theta) = A_0 + \sum_{n=1}^{\infty} (A_n \cos n\theta + B_n \sin n\theta)$$

n-even number, so \$A_n = 0, B_n = 0\$ (1)

$$V_o(\theta) = \sum_{n=1,3}^{\infty} (A_n \cos n\theta)$$
 (2)

$$A_n = \frac{4V_{pv}}{n\pi} \sum_{m=1}^p [(-1)^m \sin(n\alpha_m)]$$
 (3)

Where:

\$m = A\$ pulse number

\$\alpha = \$ The phase angle displacement

the two reference modulation techniques is inserted into the sinusoidal PWM technique to produce PWM switching signals for full-bridge inverter switches and auxiliary switch.

Table 1 : Output voltage of inverter during \$S_1\$-\$S_5\$ switch on and off.

\$S_1\$	\$S_2\$	\$S_3\$	\$S_4\$	\$S_5\$	\$V_{inv}\$
ON	OFF	OFF	OFF	ON	\$+V_{pv}/2\$
OFF	ON	OFF	OFF	ON	\$+V_{pv}\$
OFF	OFF	OFF	ON	ON	\$-\$
	or	or	or	or	\$0\$
	ON	ON	OFF	OFF	\$-\$
ON	OFF	OFF	ON	OFF	\$-V_{pv}/2\$
OFF	OFF	ON	ON	OFF	\$-V_{pv}\$

The proposed inverter is generate five-level output voltage i.e., \$0, +V_{pv}/2, +V_{pv}, -V_{pv}/2\$ and \$-V_{pv}\$. The auxiliary circuit is consists of four diodes and switch \$S_1\$, it is generate half level of PV supply voltage i.e., \$+V_{pv}/2, -V_{pv}/2\$. The five-level inverter output voltage \$V_{inv}\$ is shown in Fig.-11 and 12. Table-1 shows the level of \$V_{inv}\$ during \$S_1\$-\$S_5\$ switch ON and OFF.

The feedback controller used in this application utilizes the FUZZI- PI algorithm there is separate inverter topology to controlled. In the proposed inverter current is injected into the grid, grid current

I_g is obtained and feed back to a comparator which compares it with the reference current I_{ref} . I_{ref} is achieved by realizing the grid voltage and converting it to reference current and multiplying it with constant m . This is to confirm that grid current I_g is in phase with grid voltage V_g and always at near-unity power factor. All the algorithm are developed in C++ language and its implemented to MATLAB version. The PI algorithm:

$$u(t) = K_p e(t) + K_i \int_0^t e(\tau) d\tau \quad (4)$$

Where:

- $u(t)$ = Control signal
- $e(t)$ = Error signal
- t = Continuous-time-domain variable
- τ = Calculus variable of integration
- K_p = Proportional-mode control gain
- K_i = Integral-mode control gain
- K_d = Derivative-mode control gain

SIMULATION RESULTS

The output voltage of the PV array is 115 V and the voltage is applied DC-DC boost converter from PV array.

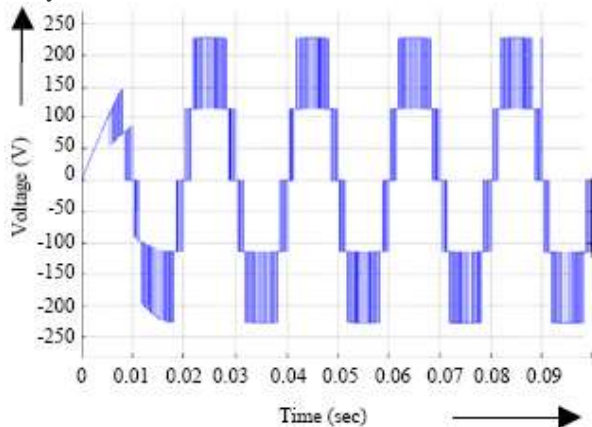

Proposed inverter output voltage

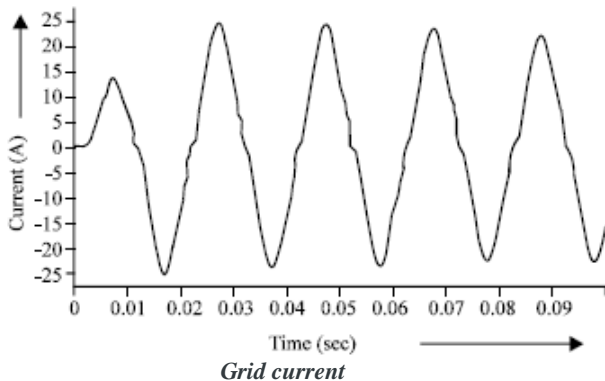

Grid current

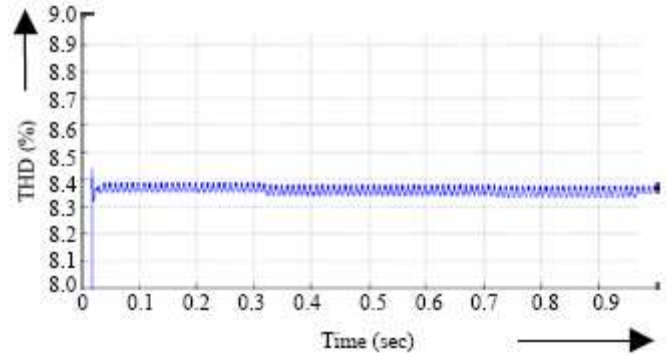

THD in FUZZY PI control scheme

RESULTS AND DISCUSSION

Some technical aspects which has been solved by PV grid connected system are:

- Harmonics for single inverter
- AC Modules
- Grounding and ground fault detection of PVsystems
- Lightning induced over voltages
- EMI of inverters
- Reclosing.
- External disconnect.
- Isolation transformer and DC-injection.
- Lower THD.
- Improved output waveform.
- Lower Electromagnetic Interference (EMI).

Need for further research in PV Grid Connected System

- Harmonics with multiple inverters.
- Effects on power network with multiple inverters.
- Islanding of inverters in a part of the network.

CONCLUSION

This study presents a single phase five level photovoltaic inverter topology for grid connected application. The photovoltaic models, operation of suggested inverter topology, control system calculations, modulation techniques and results of simulation were analyzed . The control system methods are created in computer language C++ and its implemented in MATLAB version. The fuzzy PI current controller was produced low harmonic distortion and improved sudden steps response compared to PI current controller. The grid current is nearly sine wave and the power factor also near unity. Further in the system will be applied real time application.

FUTURE SCOPE

Resulted from the world's fast growing energy demand and improvement on solar technology,

more and more large scale solar power station will be installed and connected to electric grid such as concentrated solar power (CSP). CSP systems use lenses or mirrors and tracking systems to focus a large area of sunlight into a small beam using the photoelectric effect. The first commercial CSP plant was developed in the 1980s. Since then large scale CSP plants are widely installed all over the world. Other applications in future for solar energy include solar chemical, solar vehicles and etc. More research will also focus on dynamic response and system performance when interfaced with power grid, like sudden grid voltage change, system fault both in AC and DC side, solar irradiation change.

7. A Grid-Connected Photovoltaic System with Direct Coupled Power Quality Control, Sung-Hun Ko and Seong-Ryong Lee HoomanDehbonei and C.V. Nayar.

REFERENCES

1. Power Quality in Grid Connected Renewable Energy System: Role of Custom Power Devices by S.K.Khadem, M.Basu and M.F.Conlon Electrical Power Research Group, School of Electrical Engineering Systems, Dublin Institute of Technology, Kevin Street, Dublin 8,Ireland,23-25 March 2011.
2. Analysis and Implementation of Grid-Connected Solar PV with Harmonic Compensation Jianwu Cao, Florida State University, 4 January 2011.
3. Modeling and Simulation of Grid-connected Hybrid Photovoltaic/Battery Distributed Generation System M. Makhoulf 1, F. Messai1, H. Benalla Department of Electrical Engineering, Faculty of Engineering Sciences, Mentouri University Route d'Ain El Bey, Constantine, Algeria, 1 January 2012.
4. Fault Condition Analysis in a Grid Connected PV Energy System Abbas Haijing 1, Zulkeflee Khalidin Electrical and Electronic Faculty, University Malaysia Pahang,2011 International Conference on Circuits, System and Simulation IPCSIT vol.7 (2011) © (2011) IACSIT Press, Singapore
5. Performance Analysis of 3.6 KW roof top grid connected Photovoltaic system in Egypt A.S.Elhodeiby1, H.M.B. Metwally 1 and M.A. Electrical Power Engineering Department, Faculty of Engineering, Zagazig University.
6. Modeling and Analysis of Single Phase Grid Connected Photovoltaic System,SWATI BHASME, DR. A.P. REVANKAR Research Scholar, Govt. Engineering college.